

Modelling of energy supply systems by the Balmorel model

Ramūnas Gatautis,

Hans F. Ravn

*Lithuanian Energy Institute,
Laboratory of Energy Systems Research,
Breslaujos str. 3, LT-44403 Kaunas,
Lithuania*

Analysis of the integrated development of electricity, natural gas and district heating sectors is highly relevant in Central and Eastern European countries, because in this region natural gas and district heating sectors are well developed in addition to the electricity system. The focus of this paper is on the Lithuanian energy sector.

The paper presents the bottom-up modelling of district heating networks within a model that simultaneously handles the electricity network. This permits an integrated representation of the (international) electricity system and details of local heat supply systems. The basis for the modelling was the Balmorel model, which was created for analysis of electricity sector development under liberalized market conditions. The paper presents the modification with an additional module which allows a description and analysis of energy transmission networks in more detail. The new module characterizes each segment of a network by a few basic technical-economical parameters.

The model estimates the economics in installation of new and renovation of old district heating network capacities, construction of new heat production sources, variation of final consumer's demand and scenarios of building renovation (the latter feature is very relevant for CEE countries). The paper presents an analysis of the Lithuanian situation, with an emphasis on the district heating sector. Various scenarios for the development of a small local energy supply system are described and analysed in relation to business as a usual situation: decentralization of generation, new heat sources in existing district heating networks, new cogeneration plants, introduction of heat storage and energy saving at the consumer nodes.

Key words: mathematical modelling, networks, district heating, power system, natural gas

1. INTRODUCTION

Lithuanian energy systems are well developed, but there are a number of serious problems due to the transition process from the planning economy to a liberal market. Lithuanian electricity and heat demand decreased radically during the last 15 years: power demand from 12.74 TWh (1990) to 7.94 (2003) TWh, and heat demand from 26.5 TWh (1990) to 11.3 TWh (2003) [1]. This resulted in a reduced efficiency of energy supply and more complicated operating regimes of the systems. In addition, Lithuanian Government undertook obligation to shut down the Ignalina Nuclear Power Plant till 2009, since Western experts are of the opinion that RBMK type reactors are unsafe. The Ignalina NPP is the main electricity genera-

tor in Lithuania (15.48 TWh in 2003) and covers about 80 percent of Lithuanian electricity demand, including all export (7.53 TWh in 2003) [1]. After decommissioning of the NPP the need for electricity should be covered by other plants, and a significant growth in natural gas import is possible after 2009 [6]. Russia is the exclusive energy (natural gas, heavy fuel oil, nuclear fuel) supplier to Lithuania, and securing the energy supply is a serious problem. The process of reorientation of the energy market was quick, and the energy supply system fell behind in the process. A number of problems exist in all energy supply sectors, such as generation overcapacity, high centralization; they are, obsolete and not environment-friendly, overcapacity transmission lines as well as the demand side installations not being flexible enough [5].

The district heating (DH) sector is widely developed in Lithuania. There are about 50 DH companies, including about 180 separate district heating systems (DHS), which cover about 50 percent of the total heat market in the country and about 70 percent of the heat market in the cities. Unfortunately, the transition period was very complicated for the Lithuanian DH sector, since fuel prices increased and heat demand decreased dramatically. Therefore the DH sector is inefficient and low-competitive at present.

Energy transmission networks together with fuel extraction, transformation (generation) and consumption installations constitute the basic part of modern energy supply systems. District heat transmission and distribution networks are widely developed in Central and Eastern European countries; however, they usually do not meet modern requirements. Excess capacity in district heating pipelines together with poor insulation determines high losses in heat transmission and distribution. The situation is more complicated due to very poor insulation and inefficient heat supply systems inside buildings. As a result of the mentioned problems, DH systems are low-competitive and a significant number of the end consumers wish to disconnect from the DH system and install individual natural gas heating. The threat of the collapse of the DH systems is realistic and municipalities attempt to stop this process by prohibiting disconnection from the DH systems.

DH renovation projects require huge financial means, improved social programs (large number of consumers in multi-family houses in small towns are insolvent) and the capability of municipalities to manage large-scale projects in a transparent and efficient way.

The existing situation does not meet the needs of consumers, heat suppliers and policy makers; therefore an immediate and essential reform is required in the district heating sector.

The Lithuanian practice in the last decade demonstrates that the Scandinavian model of the DH managing is not directly transferable to the Lithuanian DH business environment. The main reason for this problem is the unfinished process of the formation of public motivation and weak institutions of the protection of consumers' rights. Lithuanian economic sectors with the strongest competition and weak state regulation show the greatest progress. Therefore the introduction of competition into activities where it is possible and reasoned is a priority in new Electricity, Heat and Natural Gas laws [3].

Analysis of the energy sectors development scenarios and selection of the optimal way is a rather complicated task; therefore modern mathematical tools are needed. There are a number of mathematical tools for the evaluation of development scenarios, ranging from a technical to an economical approaches [4].

Most of the existing simulation models of the energy sector were created by Western experts and are well adapted for system simulation in Western countries, where massive and quick transformations are not as essential as in Eastern European countries. The specifics of Central and Eastern European countries require specific tools. The creation of totally new models is a long and expensive process, hence adapting the existing and in practice well tested models is a more reasonable way.

Analysis of the generation aspect alone is not sufficient for the prediction of future development: a detailed assessment of the existing networks and the possible development scenarios are also very important.

The Balmorel model is used as a basis [1]. This model was created for the simulation of power and CHP (combined heat and power) systems in the countries surrounding the Baltic Sea in the liberalized electricity market. The district heating sector in the model is represented in a very aggregated manner – as a potential heat demand for the combined heat and power technology. The idea of the authors of this article is to supplement the Balmorel model, which represents energy transmission networks, with more details for the energy sector and make it powerful and flexible enough for analysis of electricity, natural gas supply and district heating sectors as an integral whole. The paper discusses the description of the Network add-on for the Balmorel model and an implementation example from a town in Lithuania.

2. DESCRIPTION OF THE MODEL

2.1. Short description of the Balmorel model

The model is directed towards analysis of policy issues to the extent containing substantial international aspects. The model is implemented in the GAMS modelling language.

The technical structure of the Balmorel model has several main parts: the core, auxiliary tools for data input and calculation results output, and a tool for error checking in the input data. The core consists of a few files mainly including sets, variables, parameters and formulas. Other files include technical data for simulation.

The countries around the Baltic Sea are arranged in a certain hierarchy in the model. Every Country could be situated in one or more Regions and every Region could contain one or more Areas. The energy model describes interconnections among power and heat generation, energy transmission, distribution and consumption. The model gives a detailed description of generation technologies. Every electricity or heat production technology is characterized by fuel, fuel price, fuel incineration efficiency, existing and new capacities, investment, operation and

maintenance costs, lifetime, SO₂, NO_x and CH₄ emissions. The number of technologies is not limited in an Area.

Energy transmission and distribution is described by the following parameters: losses in transmission and distribution, costs of transmission and distribution, investment into new electric transmission capacities and export to the third countries.

Consumption in the model is described by annual nominal electricity demand and variation of the electricity demand during the year.

Only one electricity consumer and one heat consumer within an Area are allowed.

The time function is quite flexible in the model. The model runs on a year-by-year optimization regime. Time dimension is subdivided into two levels within a year – seasons and time segments within a season. The number of seasons and time segments within the season can vary from 1×1 (one segment and one season) up to 1×8760 (a year is represented by 8760 individual hours). 12×12 time variation is considered as standard and is typically used.

A number of different restrictions can be used. Most of them are related to the limitation of generation, investment into new generating capacities and environmental policy and tax simulation.

The model represents the supply system, including characterization of the main electricity and heat generation types with associated technical, economic and emissions related properties.

The values of the variables in the model are determined to satisfy the physical and economic principles. The physical constrains include generation opportunities using different technologies according to, *e.g.*, installed capacities and fuel availability. Transmission and distribution constrains are also satisfied along the balance between supply and demand, respectively accounting for losses and limitations. Concerning the remaining options, the variables are determined according to an economic criterion. As a result, the model determines the following parameters: generation of electricity and heat by technology and fuel; electricity transmission; emissions; investments into generation and transmission capacities; cost of electricity and heat. All these parameters are specified with respect to time period and geographical location. The solution of the model is achieved by solving a linear programming problem.

2.2. The network add-on

The Balmorel and Network add-on integration

The model consists of two basic parts: the Balmorel model Base and Network add-on. Three main files are interconnected to run the full model: Balmorel.gms, Balbase1net.sim and Network.sim. The Balmorel.gms and Balbase1net.sim include the basic codes of the Balmorel model, which are not subjected to any changes, and Network.sim includes additional

variables, equations and formulas, which are needed for the Network add-on only. Data files (*.inc) are divided into two subdirectories: Base and Network. The main data files of the Balmorel model are located in the Base directory and additional sets as well as numerical data, which are not included in the basic Balmorel model and are needed for Network add-on only, are located in the Network directory. The present implementation of the Network add-on is based on version 2.11 of the Balmorel model.

Structure of Network add-on

The structure of the Network add-on consists of three types (electricity, district heating and natural gas) of networks where a number of separate networks of the same kind is possible (*e.g.*, district heating networks).

The network is described by a graph, which includes a number of interconnected branches and nodes.

Branches in the model represent physical networks (pipelines, cables), network installations (*e.g.*, power transformer) or some specific features (*e.g.*, renovation of old buildings and the related reduction of heat demand). Nodes are connectors for branches and are related with technologies, *i.e.* every technology must be related with some node. Interconnections among the networks are defined in the nodes. The networks are somewhat simplified in order to reduce the number of variables in the model. Furthermore, the simplifications ensure the possibility of introducing separate district heating systems to the model or describing one in a more detailed way. The idea is to keep flexibility between two extremes: i) to describe a network as one branch with average aggregated parameters; and ii) to describe a network with a number of physical parameters for each unit in the network.

There are no estimated physical factors like pressure, velocity of the heat carrier, hydraulic processes in DH pipelines, voltage losses, reactive and active power flows in the power grid, etc. These assumptions may influence the model accuracy when compared to specialized models for district heating, power or gas supply systems respectively. However, this does allow the covering of large energy systems for one or more countries and long-term development analysis for all sectors as a combined system.

The model is rather flexible in simulating one, all or any combination of electricity, heat and gas networks.

Nodes

There are three types of nodes in the expanded model by the energy form: electricity, heat and gas. Therefore there are three subsets of nodes and they need not to be mutually exclusive, some nodes can be presented in more than one subset. A common node between two or three networks is a point con-

taining an energy transformation technology. A node represented in only one network may contain a technology too, *e.g.*, oil-fired boiler or heat storage.

All production and demand nodes are linked to the areas. Each area can include a number of production units and a number of final demand nodes (consumers). The final consumer could be an electricity, heat or gas consumer. The technology using natural gas or a heat pump is not considered as the final consumer.

The first of Kirchhoff's laws is valid for all nodes: the sum of incoming flows is equal to the sum of outgoing flows.

The energy balance equation at the node $n \in N$ for each time period $t \in T$:

$$\begin{aligned} \sum_{i=1}^I (\eta_{i,n,t} * F_{i,n,t}^{flow}) + F_{n,t}^{FI} + \sum_{s=1}^S F_{s,n,t}^{unload} + \sum_{g=1}^G P_{g,n,t} &= \\ = \sum_{j=1}^J F_{j,n,t}^{flowout} + \sum_{s=1}^S F_{s,n,t}^{loadup} + \sum_{c=1}^C D_{c,n,t} & \quad (1) \end{aligned}$$

where $F_{i,n,t}^{flowin}$ an inflow to the node n by branch i connected to node n in each time interval t ;

$\eta_{i,n,t}$ energy losses in the branch i connected to node n in each time interval t ;

$F_{n,t}^{FI}$ Fixed Input of energy introduced to the node n in each time interval t ;

$F_{s,n,t}^{unload}$ energy unloaded from a storage s to the node n in each time interval t ;

$P_{g,n,t}$ generation of technologies g related with the node n in each time interval t ;

$F_{j,n,t}^{flowout}$ outgoing flow from the node n by the branch j connected to this node n in each time interval t ;

$F_{s,n,t}^{loadup}$ load of energy to a storage s related with the node n in each time interval t ;

$D_{c,n,t}^n$ demand of the consumer c related to the node n in each time interval t ;

T number of time periods selected;

N number of nodes in the energy system.

Branches

The expanded model has three sets of branches for each type of energy transportation network: electricity, heat or gas (Fig. 1). Any branch is in one and only one of these sets. The model can handle different graphs of various complexities, from a very simple scheme including just one branch to more complicated schemes with several branches. In fact, the existing code allows introduction of both generation

technology and demand in one node. But in this case it is not possible to estimate any network parameters. Therefore it is recommended to have at least one branch between the generation node and the demand node if the network performance is analyzed.

Every branch includes the following parameters: capacity (MW), losses (percent / 100, values from 0 to 1 are used), fixed O & M cost (euro / MW), variable O & M cost (euro / MWh) and investment cost (for branches that simulate the new capacity) (euro / MW).

In general, all branches may contain two-direction flows. However, there are two types of branches in the model; the first type contains branches where both flow directions share the same parameters (capacity, losses, fixed costs, variable costs and investment costs are the same). The second type contains branches where the direction "plus" and the direction "minus" have different parameters. For example, consider a branch having different parameters for two flow directions. The capacity of the direction "plus" is 10 MW and the capacity of the direction "minus" is 1 MW.

A loss value in the branch is estimated at the incoming side of the flow to a node for the variable representing the inflow to the node. It is possible to have different values of losses during a year (for each season segment which by default means a month) or one value per year. This possibility results in a better simulation of heat losses in district heating pipelines, because in reality relative heat losses in winter and summer periods could be very different.

For the expanded model, it is possible to introduce new branches into the network. This could be either a parallel branch to replace an already existing one or an entirely new branch. New branches are only possible where the user of the model allows this. New possible branches have the same parameters as the existing branches, except the capacity, which is variable and a result of the simulation. The investment costs are estimated for new branches only. If a new branch is introduced in parallel to an old existing branch, the old branch is eliminated. This feature is important to avoid the situation where a new small additional capacity is added every year to the existing capacity.

The elimination of old branches is stated as

$$\begin{aligned} F_i^{flow} &\leq z_1 * K; \\ F_i^{flow} &\leq z_2 * C; \\ z_1 + z_2 &\leq 1; \\ z_1 &\in [0,1], z_2 \in [0,1] \end{aligned} \quad (2)$$

where F_i^{flow} energy flow in a branch in each time interval;

z_1 binary variable representing the possibility of flow in an existing (old) parallel branch;

z_2 binary variable representing the possibility of flow in a new parallel branch;

K the installed capacity of an existing (old) parallel branch;

C some big number (bigger than the possible flow value in a branch).

E.g., the existing capacity is 10 MW; the branch capacity needed next year is 12 MW, therefore the model made an investment in 2 additional MW. The second year this is repeated again and a 3 MW capacity is added. In practice, it is impossible to add a new small DH or gas pipeline parallel to an existing pipeline. Therefore the model can choose, *e.g.*, 15 MW (or some other given number) of the new installed capacity in the second year of a simulated period.

This ensures the correct simulation of the renovation of existing lines and installation of new energy transportation lines. This feature uses mixed integer programming (MIP), and the calculation time is longer compared to linear programming (LP). Therefore it can be turned off, and only LP is used if the model does not make the above-mentioned error, and in this case shorter calculation time is needed.

Fuel supply

The fuel supply is designed in such a way that every energy production (transformation) technology uses one or more types of fuel (*e.g.*, heavy fuel oil and natural gas) or the same type of fuel with different characteristics (*e.g.*, heavy fuel oil, but of different prices and sulphur content). It is possible to limit the capacity of natural gas supply (*e.g.*, due to limitation of existing natural gas pipeline capacity) and the investments into new capacities. Together with the supplied fuel prices, it is possible to estimate the variable and fixed costs of fuel supply (*e.g.*, costs of peat storage). This allows analyzing the competition between natural gas, autonomous heating and district heating technologies along with the estimations of topography for both networks.

Production

Every node in the model can be linked to a production technology. One node can have zero, one or more production technologies. The user of the model decides which combinations of technology and nodes are permitted. The number of production units is not limited in the model. The outcome of the simulation shows which technology produces energy

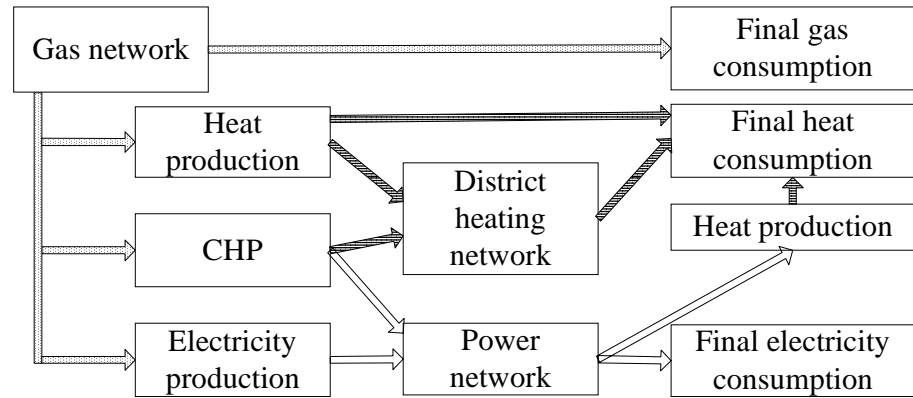

Fig. 1. Structure of the model

and the volume of the production. Generation technologies are described by several parameters, making the analysis quite detailed. The capacity of existing technologies is limited by installed capacity, but the capacity of new installed technologies is variable and is not limited.

The possibility of fixing the input of energy to the node is introduced. This means that a fixed amount of energy in terms of a constant could be added to every node. This feature allows simulation cases where the network has to use energy from specific sources, *e.g.*, waste incineration plants. International energy flows, *e.g.*, electricity or gas transit, may be modeled in a similar way.

Demand

Every heat, electricity and gas demand node can be linked with energy consumer. The demand is described by two parameters: demand value per year and demand profile during the year. The typical consumers (household, commercial, etc.) could be represented by a general demand curve, while large or important consumers (*e.g.*, large industry) should have a personal demand curve. Demand curves depend directly on the time representation in the model.

Storages

The model has the possibility of simulating the energy storages, even electricity, heat and natural gas, which work as part of the network infrastructure. The storages for different types of energy could be simulated separately, all together or in any combination. Storage technology is introduced to a node, and every node can have one storage technology for the same type of energy, *e.g.*, one electricity, one heat and one gas storage technology (provided this node is part of the electricity, heat and gas networks) is allowed in one node, but, *e.g.*, two electricity storages is illegal.

The size of the storage could be defined by the user as existing technology or could be installed as a new capacity. The operation, maintenance and investment costs and losses for energy storages should be given.

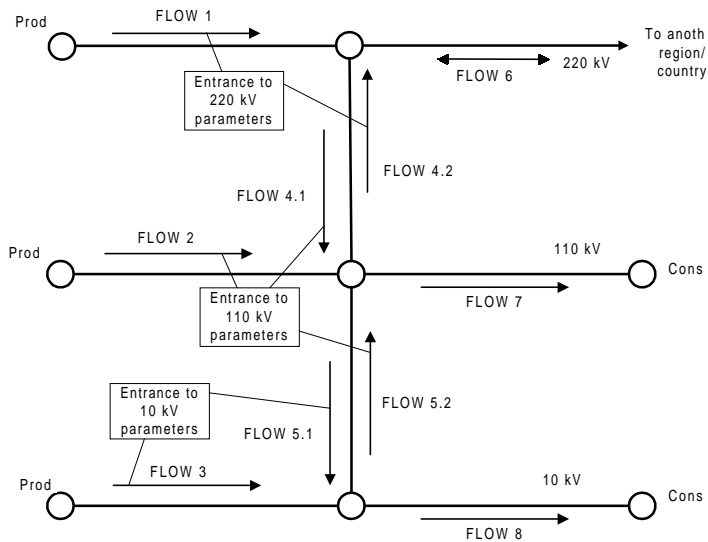

Fig. 2. Possible electricity network interpretation in the model

Model adaptation for specific needs

The model also allows the simulation of the impact of insulation and renovation of the energy supply system. The heat demand node, which represents heat consumption of one or more buildings, could be “extended” by some additional branches representing heat losses in a building element (*e.g.*, windows, walls and heat distribution installations) and has a parallel branch which represents reduced building losses after renovation and includes investment needs for renovation. Such pairs of branches could be connected in series and represent several different elements of a building.

The extended model, for the electricity level, allows representation of different voltage levels. Generally, the electricity network is more complicated than the district heating network, so the network is quite simplified and focus is held on different tariffs and losses on different levels of voltage. Figure 2 illustrates the idea.

All producers and consumers are connected to the power grid on the actual voltage level. Suppose a producer is connected to a 10 kV grid. In this case, the parameters of Flow 3 represent cost (could be fixed or / and variable) and losses of the 10 kV network. It is possible for the electricity in the 10 kV grid to flow in two directions: to the consumer which is connected to this voltage or to a higher voltage grid (110 kV in this example). In this case, Flow 5.2 has parameters for entrance to the 110 kV grid: losses and cost for this network. In this example, electricity produced in the 10 kV (Flow 3) is obliged by the losses and cost of the 10 kV network and can be transmitted: i) to the 10 kV consumer (without any additional losses and cost), ii) to the 110 kV grid (Flow 5.1) (losses and cost of 10 kV grid will be estimated), iii) to the 220 kV network (Flow 4.2) (losses and cost of 220 kV network will be estimated).

3. APPLICATION OF MODEL FOR HEAT SUPPLY ANALYSIS

The expanded model could be used for the analysis of different sizes of tasks, both large systems and relatively small ones. The authors defined the primary scope of the project to present a model for the analysis of Lithuanian power, natural gas and district heating sectors with emphasis on CHP technology. However, in the progress of the project a serious problem of data collecting arose, especially from the DH sector. There is no centralized detailed data collecting system from the Lithuanian district heating companies at present. District heating companies are monopolists and cannot be considered as the paragon of transparency. Therefore the full scale Lithuanian DH, power and gas sector model is not available at the moment. The Lithuanian District Heating Long Term Development Plan was approved. This document declared the creation of the National Database for the energy sector. However, the database filling process is a rather time-consuming procedure. In the following sections we present the possibilities of the model and the simulation on the example of a town in southern Lithuania.

3.1. Town district heating description

The district heating system of Eiskes town was constructed in 1970. At present, the Eiskes district heating system is operated by a large company, which includes 10 separate DH systems in separate towns. The DH scheme of the town is presented in Fig. 3. The existing system has two heat only boilers situated in one boiler house, and the total installed capacity is 8.35 MW. The main fuel is heavy fuel oil, but sometimes crude oil is used (4 percent in 2002). The total length of the DH network is 1588 m and the diameter varies from 50 mm up to 250 mm. All consumers are buildings (no industry): the municipality, hospital, 3 schools and 5 multi-family houses. The demand per season varies significantly – from 645 MWh in December to 55 MWh in July 2002. The big difference in demand variation during a year is due to the climate and the fact that the schools do not use tap water in summer. The pipelines were constructed 35 years ago, therefore the insulation is obsolete and of reduced quality. Average annual heat losses from the pipelines during a year are about 25 percent. However, the heat losses in summer and in winter differ significantly (16 percent in December and 58 percent in July 2002).

Three networks are introduced into the model describing the town’s energy supply system: district heating, electricity and natural gas. The main heat supplier is the DH system. Electricity is seldom used

for space heating due to the high price (the electricity tariff is approximately 2 times higher than the DH tariff). Electricity is used for heating when DH does not provide heat at the start of the heating season (heat demand regulation on demand side has not been introduced up till now and the heating season starts at the same time for all consumers) or as additional source of DH, if some of the consumers are not satisfied with the quality of the heat supply. This is due to the fact that heating systems in a number of existing buildings are poorly tuned, hence somewhere overheating occurs whereas underheating is a problem elsewhere in the same building.

The town power network is described by two voltage levels. The 10 kV voltage level is connected to the national power grid and energy through the transformer is supplied to the 0.4 kV consumers (Fig. 4). The electricity needs of all consumers for heating purposes only are not represented in the model.

There is no natural gas network in the town at present. However, natural gas networks are widespread in Lithuania, and the number of household customers connected to the natural gas network was 518000 in 2003. Therefore, the natural gas network development scenario is also analyzed.

The investment cost is associated with the annuity factor in the model, and the value 0.149 is used for calculation (corresponding to annuity payment over a lifetime of 10 years and an interest rate of 8%).

3.2. Scenario 1. No essential changes (Table 1)

No essential changes means that only new generation units are allowed in the DH. This is the main strategic scenario of the existing DH company: the change of a heat boiler to a new one, which uses cheaper fuel. Wood fuel is the cheapest type of fuel for small boilers in Lithuania at present. Two possible locations for the new units are presented in the model. The first location is the existing boiler-house (point A, see Fig. 3). Another possible location is at the other end of the main pipeline, near the large consumers – the Municipality building and the Hospital (point B, see Fig. 3).

Some main parameters used for all scenarios are: the price of heavy fuel oil 500 LTL/t (1 euro = 3.4528 Lt), the price of wood fuel 100 LTL/m³ and heat demand of the end-users is fixed and equals 3558 MWh/year.

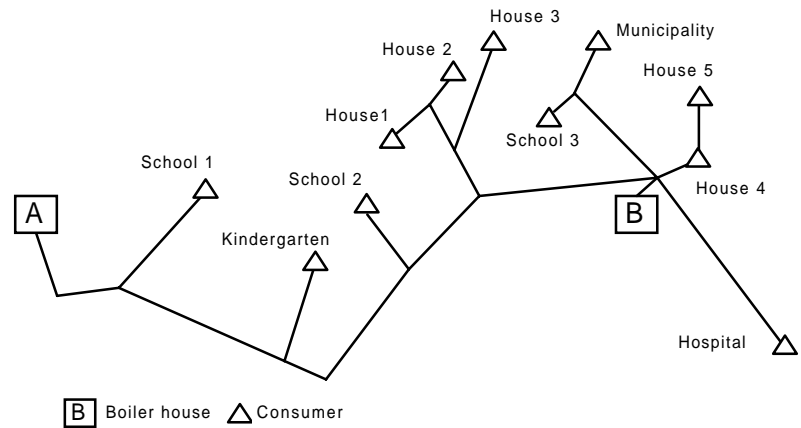

Fig. 3. Eisiskes town district heating scheme

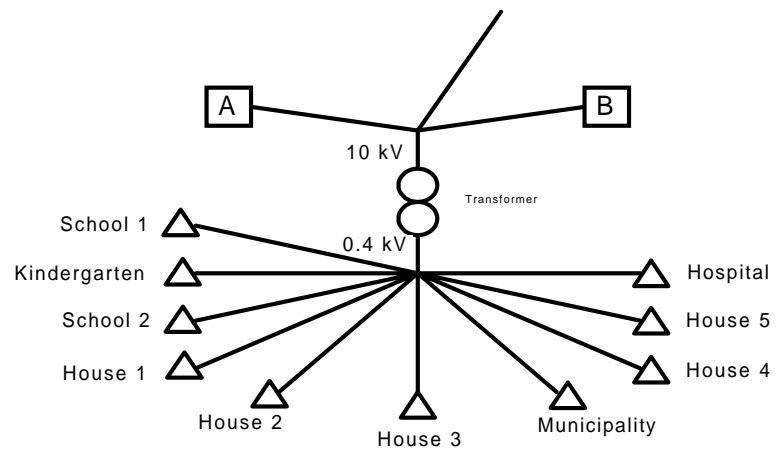

Fig. 4. Electricity network for the Eisiskes town model

Case I. Existing situation. Results of calculation correspond to the real data presented by the DH company.

The analyzed cases within the scenario are as follows:

Case II. The new wood burning boiler is assumed to locate in the existing boiler house (point A, see Fig. 2).

Case III. The new wood boiler is assumed to locate in point B (see Fig. 2).

Case IV. The new wood boilers are assumed to install in two points A and B (see Fig. 2).

Case V. The new wood burning CHP could be installed in point A.

In case III, the investment in boilers at point B is estimated as two times higher than for a new boiler in point A, because a new boiler-house with the whole infrastructure in point B is needed. Investment in the expansion of the DH pipelines is required in no cases of this scenario because of the sufficient existing capacity.

In case V, the assumption is made that electricity generated at wood CHP is sold to the national electricity market for 200 LTL / MWh and the wood CHP installation cost is 1000 euro / kW_{el}.

Table 1. Scenario 1 calculation results

	Scenario 1, case I. Existing heavy fuel oil boiler	Scenario 1, case II. Wood boiler and existing oil boiler in point A	Scenario 1, case III. Wood boiler in point B	Scenario 1, case IV. Wood boilers in points A and B	Scenario 1, case V. Wood CHP in point A
Newly installed generation capacities, MW	–	Wood boil.0.503	Wood boil. 0.634	Wood boil. A 0.596 Wood boil. B 0.634 Total 1.23	CHP 0.605 (el)
Investment to new generation, kLTL	–	Wood boil. 151	Wood boil. 380	Wood A boil. 179 Wood B boil. 380 Total 559	CHP 2090
Heat (electricity) generation, MWh/a	4754	Wood boil. 3141 Oil boil. 1613 Total 4754	Wood boil.2884 Oil boil. 1459 Total 4343	A boiler 1666 B boiler 2688 Total 4354 Oil boil. 20	CHP 4734 th (2367 el) Oil boil. 20 Total heat 4754
Fuel consumption, MWh/a	5593	Wood boil.3696 Oil boil.1897 Total 5593	Wood boil. 3327 Oil boil. 1717 Total 5044	A boil. 1960 B boil. 3089 Total 5049	CHP 8876 Oil boil. 24 Total 8900
Expenses for fuel, kLTL/a	191185	Wood 81 Oil 65 Total 146	Wood boil. 73 Oil boil. 587 Total 132	A boil. 43 B boil. 68 Total 111	CHP 195 Oil boil. 0.8 Total 196
Losses in DH network, MWh/a	1196	1196	796	796	1196
Generation cost, LTL/MWh	88.9	80.4	86.1	67.8	201.5
DH network cost, LTL/MWh	31.1	31.1	26.4	26.7	31.1
Total cost, LTL/MWh	116	111.5	112.5	94.5	99.4
Total expenses per system, kLTL/a	413	397	400	336	354

3.3. Scenario 2. Possible replacement of DH pipelines (Tables 2 and 3)

The technical state of existing heat supply pipelines is rather poor. Replacement of pipelines with new ones with better insulation and optimized diameters should reduce heat losses in the transmission network and improve the dispatching of hydraulic processes. The density of demand is changed, and a new optimal configuration of pipelines should be found. The model has the possibility of simulating the renovation of pipelines. Existing and new pipelines are described as a number of interconnected segments, which are defined by the capacity (existing or newly installed), losses, and operation and maintenance costs. The results of the simulation could be the replacement of all segments by new ones, changing part of the segments or no changes at all.

The cases analyzed within the scenario are as follows:

Case I. Wood boiler generation in point A. Replacement of DH pipelines is allowed.

Case II. Wood boiler generation in point B. Replacement of DH pipelines is allowed.

Case III. Wood CHP generation in point A. Replacement of DH pipelines is allowed.

The location of generation sources in the network has a significant impact on the final solution. When new pipelines are installed and losses in the network are reduced, smaller generation capacity is needed, since less heat is required.

Estimation of the renovation of the demand side is another very important issue in the analysis of DH development. Nearly all buildings constructed during the soviet period have a very poor insulation.

Table 2. Scenario 2 calculation results

	Scenario 2, case I. Wood boiler in point A. DH pipe renovation	Scenario 2, case II. Wood boiler in point B. DH pipe renovation	Scenario 2, case III. CHP in point A. pipe renovation	Scenario 2, case IV. All “saving” measures, wood boiler in point A	Scenario 2, case V. All “saving” measures, wood boiler in point B	Scenario 2, case VI. All “saving” measures, CHP generation in point A
Length of newly installed pipelines, m	1588	1588	1588	1588	1588	1588
Investment into new pipelines, kLTL	1209	1209	1209	677	677	676
Newly installed generation capacities, MW	Wood boil. 0.399	Wood boil. 0.357	CHP 0.512 el. (1,024 th)	Wood boil. 0.223	Wood boil. 0.200	0.287 el (0.573 th)
Investment to new generation, kLTL	Wood boil. 120	Wood boil. 214	CHP 1768	Wood boil. 67	Wood boil 120	CHP 989
Heat (electricity) generation, MWh/a	Wood boil. 2318 Oil boil. 1420 Total 3738	Wood boil. 1230 Oil boil. 2488 Total 3718	CHP 3720 th (1860 el) Oil 18 Total 3738	Wood boil. 1297 Oil boil. 794 Total 2091	Wood boil. 689 Oil 1391 Total 2081	CHP 2081 th (1041 el) Oil boil. 10 Total 2091
Fuel consumption, MWh/a	Wood boil. 2727 Oil boil. 1670 Total 4397	Wood boil. 1414 Oil boil. 2928 Total 4342	CHP 6975 Oil boil. 21 Total 6996	Wood boil. 1526 Oil boil. 935 Total 2461	Wood boil. 792 Oil boil. 1637 Total 2429	Oil boil. 12 CHP 3903 Total 3915
Expenses for fuel, kLTL/a	Wood boil. 60 Oil boil. 57 Total 117	Wood boil. 31 Oil boil. 100 Total 131	CHP 153 Oil boil. 0,7 Total 154	Wood boil. 33 Oil boil. 32 Total 66	Wood boil. 17 Oil boil. 56 Total 73	Oil boil. 0,4 CHP 86 Total 86
Losses in DH network, MWh/a	180	161	180	101	90	101
Generation cost, LTL/MWh	68.8	76.8	169,2	86.8	94.8	187.2
DH network cost, LTL/MWh	55.8	54.8	55.8	55.9	54.8	55.9
Total cost, LTL/MWh	124.7	131.6	120.4	142.7	149.6	138.4
Total expenses per system, LTL/a	444	468	428	857	871	849

Table 3. Scenario 2. Buildings renovation investment

	Renovation heating equipment of buildings	Replacement of windows	Insulation of basement, walls and roof	Total
Investment to “heat saving” measure, total all consumers, kLTL	797	797	2253	3847
Decrease of heat losses, per cent	25	7	12	44

Table 4. Scenario 3 calculation results

	Scenario 3, case I. Total decentralization. Individual wood boilers	Scenario 3, case II. Total decentralization. Individual electric heating	Scenario 3, case III. Total decentralization, individual wood boilers. All "saving" measures	Scenario 3, case IV. Central oil boiler, individual wood boilers	Scenario 3, case V. Central wood boiler in point A and individual electric heating. New DH pipelines
Newly installed generation capacities, MW	1.122	1.177	0.628	Indiv. wood boil. 0.182	El. heat. 0.182 Wood boil. 0.919
Investment to new generation, kLTL	225	118	126	36	El. heat. 18 Wood boil. 275 Total 294
Heat generation, MWh/a	3558	3558	1991	Ind. boil. 1192 Oil boil. 2940 Total 4132	El. heat. 1192 Wood boil. 2429 Total 3621
Fuel consumption, MWh/a	4448	3801*	2489	Wood boil. 1490 Oil boil. 3459 Total 4949	El. heat. 1308 Wood 2858 Total 4166
Expenses for fuel, kLTL/a	98	961	55	Wood 33 Oil 118 Total 151	El. heat. 353 Wood 63 Total 416
Losses in DH network, MWh/a	0	0	0	574	63
Generation cost, LTL/MWh	48.3	280	89.2	73.2	46.6
DH network cost, LTL/MWh	0	0	0	28.05	53.59
Total cost, LTL/MWh	48.34	280	89.2	101.2	100.2
Total expenses per system, kLTL/a	172	996	751	360	357

* The amount of consumed electricity.

In addition, the existing technical system does not allow regulation of the heating intensity in every room of the heat consumer. Such a system is passive and inefficient. The situation could be improved by partial or full renovation of the buildings. The model has the possibility to simulate optimal renovation of the buildings. It is arranged in such a way that each consumer node is "extended" by three pairs of branches. One branch simulates renovation of heating installations inside the buildings (new substation, additional balancing pumps, regulation valves on radiators, etc). The second branch simulates replacement of existing old windows by new ones with modern frames and windowpanes. The third branch simulates renovation of building insulation (basement, walls and roof). Every branch has a parallel branch. One branch describes the existing situation (heat losses

in percentage) and the other describes the renovated situation when losses are reduced and certain investments are needed.

All consumers are buildings in the presented town model, therefore "heat saving" measures are allowed for all consumers.

When losses on the heat demand side are reduced the demand decreases, therefore smaller transmission and generation capacity is required. Below are presented the results of the simulation situation when all "heat saving" measures are introduced in the different generation points. Due to "heat saving" measures the final demand is reduced by 1991 MWh / year.

3.4. Scenario 3. Essential structural changes are allowed (Table 4)

This scenario analyses the possible decentralization of heating in the town. As is mentioned above, a num-

Table 5. Scenario 4 calculation results

	Scenario 4, case I. Gas boiler in point A		Scenario 4, case II. Individual gas boilers	Scenario 4, case III. Gas CHP in point A
Newly installed generation capacities, MW	1.299		1.122	0.455 el. (1.299 th)
Investment, kLTL	Gas main pipe 3370 Gas boiler 538		442	785
Heat (electricity) generation, MWh/a	4754		3558	4754 th (1664 el)
Fuel consumption, MWh/a	5593		4448	7551
Expenses for fuel, kLTL/a	251		215	339
Losses in DH network, MWh/a	1196		0	1196
Generation cost, LTL/MWh	107.2		90.6	161.38
DH network cost, LTL/MWh	172.2*	31.12**	0**	31.12**
Total cost, LTL/MWh	279.4*	138.3**	90.6**	145.6**
Total expenses per system, kLTL/a	994*	492**	446**	518**

* Main gas pipeline construction included.

** In the case the main gas pipeline construction is not included.

ber of consumers in Lithuania are not satisfied with the quality and tariffs of the DH company and wish to disconnect from the district heating network and install individual heating. Natural gas is the main alternative to DH in large cities, while natural gas, wood, coal, light fuel oil, liquid gas are attractive in small towns. The question is how such disconnections will impact economics and the DH network operating as well as other energy suppliers (natural gas, electricity) What is more attractive, DH or total decentralization? Those questions are very important for energy suppliers, municipalities, designers, consumers and policy makers.

This scenario analyzes the following cases.

Cases I and II. Total decentralization, when district heating is rejected as a technology. In this case all consumers install new individual heat sources. The analyzed options are wood boilers (Case I) or electric heating (Case II).

Case III. Total decentralization with estimating the introduction of “heat saving” measures into buildings.

Replacement of district heating by individual wood boilers is a good option from the economic point of view, but numerous of small boilers will debase the air quality in the town. The model can calculate the pollutants, but it cannot answer whether these emissions meet the norms of their allowed concentrations in the air. Electric heating is not attractive due to the high electricity tariff.

Case IV. Partial decentralization. This case analyzes the situation when only decentralized small boilers operate in the summer time when heat demand is low. DH and small decentralized boilers operate together during the heating season. The attractiveness here is to avoid big losses in the DH network when the demand is low.

3.5. Scenario 4. The natural gas network introduction (Table 5)

There is no natural gas supply network in the town. A possible natural gas network was introduced into

the model with the same configuration as the district heating network, *i.e.* an assumption is made that gas network segments would be constructed in parallel to the DH. The main line of the natural gas pipeline is situated 15 km away from town, therefore construction of such a pipeline and a pressure reduction station is needed.

The pipeline from the main gas pipe to the town is very expensive and not attractive due to the relatively low demand. However, in case the town has gas supply to the central boiler house, the construction of gas pipelines to individual gas boilers would be attractive. This case is presented as an example of the model possibilities, since many Lithuanian towns have well-developed gas supply networks, and total decentralization along with installation of individual gas boilers does not, in most towns, require investment in the extension of the existing gas network.

4. DISCUSSION

The analyzed cases of heating system development in the Eisiskes town have been grouped and are presented in Table 6. The results has shown that the cheapest way to supply heat is total decentralization and an individual wood boiler for each heat consumer. However, this way has a drawback: numerous small wood boilers can debase the air quality in the town and require quite a bit of hand work in exploitation.

The case “do nothing”, *i.e.* no changes, no investments takes the 8th position, therefore at least 7 cases are better. Three of those cases assume a change of the generation structure and installation of new wood boilers which use a cheaper wood fuel. As compared to other alternatives, this way of development requires relatively small investments. The other two cases assume partial heating system decentralization,

Table 6. Ranking of analyzed cases according to total expenses for heat supply in the town

Cases of heat supply development in the town		Total expenses per system, kLTL / a
1	Scenario 3, case I. Total decentralization, individual wood boilers	172
2	Scenario 1, case IV. Wood boilers in points A and B	336
3	Scenario 1, case V. Wood CHP in a point A	354
4	Scenario 3, case V. Partial decentralization. Central wood boiler in point A and individual electric heating. New DH pipelines	357
5	Scenario 3, case IV. Partial decentralization. Central oil boiler, individual wood boilers	360
6	Scenario 1, case II. Wood boiler and existing oil boiler in point A	397
7	Scenario 1, case III. Wood boiler in point B	400
8	Scenario 1, case I. Existing heavy fuel oil boiler (no any changes)	413
9	Scenario 2, case III. CHP in point A, DH pipe renovation	428
10	Scenario 2, case I. Wood boiler in point A, DH pipe renovation	444
11	Scenario 4, case II. Total decentralization. Individual gas boilers	446
12	Scenario 2, case II. Wood boiler in point B. DH pipe renovation	468
13	Scenario 4, case I. Gas boiler in point A (without main gas pipe investment)	492
14	Scenario 4, case III. Gas CHP in point A (investment to main gas pipe does not estimated)	518
15	Scenario 3, case III. Total decentralization, individual wood boilers. All "heat saving" measures	751
16	Scenario 2, case VI. All "heat saving" measures, CHP in point A	849
17	Scenario 2, case IV. All "heat saving" measures, wood boiler in point A	857
18	Scenario 2, case V. All "heat saving" measures, wood boiler in point B	871
19	Scenario 4, case I. Gas boiler in point A	994
20	Scenario 3, case II. Total decentralization, individual electric heating	996

when only individual boilers work in a non-heating season and central DH boiler in parallel with individual boilers work in heating season time.

Small-scale CHP units working on wood chips are attractive also. They greatly depend on the tariff of electricity provided to the national electricity grid. The preferential tariff for electricity produced from renewable sources is applied in Lithuania at the moment (200 LTL / MWh).

All other cases are more expensive, but to conclude that they are worse would be not correct.

The possibility to install CHP units would be much more attractive in case the price of electricity increases. The rise of electricity price is very realistic due to the fact that the Ignalina Nuclear PP will be closed in 2009.

The possibility to renovate the insulation of old district heating pipelines and buildings looks more realistic in the light of discussion on the implementation of the national building sector development strategy and the possibility to use European structural funds. Together with the aim of the European Commission to decrease the import of energy resources from non-EU countries, the investments to reducing fuel use are attractive.

5. CONCLUSIONS

Sustainable development of the energy sector, including power, district heating and natural gas supply sub-sectors, is a complicated task. This task has spe-

cific features in Lithuania and Central and East European countries due to requirements to re-orient the energy sector from planning economy to the liberal market and avoid threats of a single geopolitical energy supplier.

For the analysis of such specific features, the network expansion of the Balmorel model has been created. This add-on expands the original model with a more detailed description of district heating, natural gas and electricity networks. It allows an analysis of different development scenarios and renovation of the energy generation, transition and demand side. This is a powerful and flexible mathematical tool in the political and economic decision-making for development of the energy sector at a national, regional or municipal level.

The article provides a description of the expanded model and analyzes the heat supply scenarios on an example of a Lithuanian town called Eisiskes. Nineteen cases are analyzed within four scenarios.

The results show that decentralizing heat supply would be attractive from the economic point of view; however, it can debase the air quality in the town. In addition, introduction of CHP technology would be impossible in the case of total decentralization. Reconstruction of district heating pipelines and a comprehensive renovation of buildings would have an essential impact on the improvement of the consumers' comfort level, reduction of fuel consumption and emissions, therefore it should be attractive from the national energy policy implementation point of view.

ACKNOWLEDGEMENT

The project has been supported by the Nordic Energy Research program of the Nordic Council of Ministers.

Received 01 June 2005

References

- 1. Energy in Lithuania. Lithuanian Energy Institute. ISBN 9986-492-81-5.
- 2. Balmorel model page. www. Balmorel.com.
- 3. Gatautis R. Regulation and competition in the Lithuanian district heating sector // Energy & Environment. 2004. Vol. 15. No. 2. P. 297-307.
- 4. Tarvydas D. Energetinės sistemos plėtros analizei skirtø modeliø apžvalga // Energetika. 2005. Nr. 1. P. 40-45.
- 5. Norvaiša E., Galinis A. Įoriniø energijos gamybos kaštø ŗtaka Lietuvos energetikos sistemos funkcionavimui ir darniai plėtrai // Energetika. 2004. Nr. 2. P. 1-8.
- 6. Galinis A., Norvaiša E. Electricity supply scenarios in Lithuania after closure of the existing nuclear power plant // Proceedings of the 5th international conference on nuclear options in countries with small and medium elecricity grids, Dubrovnik, Croatia, May 16-20, 2004. Dubrovnik, Croatia, 2004. P. 1-8.

Ramūnas Gatautis, Hans F. Ravn

ENERGIJOS TIEKIMO SISTEMØ MODELIAVIMAS BALMOREL MODELIU

Santrauka

Vidurio ir Rytø Europos ŗalys turi gerai įvystytus elektros, gamtiniø dujų ir centralizuoto ŗilumos tiekimo sektorius. Darni ŗio sektoriø plėtra turi bŗti analizuojama kompleksiška.

Straipsnyje pateikiamas poreikiais grindžiamas (bottom-up tipo) matematinis optimizacinis modelis Balmorel, praplėstas autoriø sukurtu moduliø „Tinklai“. Originalus modelis Balmorel kurtas ŗalio apie Baltijos jŗrø elektros sistemoø ilgalaikei plėtros analizei. Įoplėstas modelis, apimantis gamtiniø dujų bei centralizuoto ŗilumos tiekimo tinklø analizæ, leidžia vertinti esamo ir galimo naujo elektros bei ŗilumos ŗaltiniø poreiká, elektros, CDT ir gamtiniø dujų tinklø tiesimà ir rekonstrukcijà, elektros ir ŗilumos apkrovos grafikø kitimo ŗtakà tiekimo sistemoms, taip pat pastatø rekonstrukcijos, siekiant sumažinti ŗilumos nuostolius juose, ŗtakà energijos tiekimo sistemoø plėtrai.

Pateikiamas išplėsto modelio pritaikymo miesto ŗilumos tiekimo sistemos plėtros analizei pavyzdys, vertinant naujo katilø, termofikacinės jėgainės ŗrengimà, CDT vamzdynø renovacijà, pastatø atnaujinimà ir ŗilumos vartojimo sumažėjimo ŗvairias kombinacijas, taip pat ŗilumos tiekimo decentralizavimà.

Raktaþodžiai: matematinis optimizacinis modelis, tinklai, centralizuotas ŗilumos tiekimas, elektros sistema, gamtiniø dujų sistema

Ðaì íí àñ Áàòàòòèñ, Ááíñ Ò. Ðááí

**Į Į ÁÁĖĖÐĮ ÁÁÍ ĖÁ ÝÍ ÁÐÁÍ ÑĖŅŌÁÍ
Į Į ÁÁĖŪ BALMOREL**

Ðaçþìà

Ņòðáí Ū Ōáí òðàèüí íé è Áí ñòí-ííé Ááðí í Ū í áèááàþò í á òí èüèí òí ðí òí ðaçàèòíé ñèñòáí íé ýèàèòðí ñí ááæáí èý, íí è ñèñòáí àì è òðáí ñí í ð-òèðí áèè í ðèðí áí íáí áàça è òáí òðàèèçí ááí í íáí òáí èí ñí ááæáí èý. Áí áèèç èò ðaçàèòèý ñèááòáò í ðí áí àèòü, ðáññí àòðèááý áñà ýòè ñèñòáí Ū á ñí áí èóí í í ñè.

Á í áñòí ýùáè ñòáòüá í ðááñòááèá í à òáí àðè-áñèáý í í òèí èçàòèè í í áý í í ááèü, ñí çááí í áý í í ðèí òèí ó, èí ááá çáááí í áý í í òðááí í ñòü á ý í áðáèè í ááñí á-áí á í ò óæá èí áþùèòñý ááí áðèðòþùèò í í ū í í ñòáè (bottom-up) èèè òáò, èí òí ðŷá í í áòò á ūòü í í ñòðí áí Ū á áèèææèòáí áóáóŷáí. Çà í ñí í áó á ūèá áçýòá í í ááèü Balmorel, í ðááí áçí á-áí í áý áèý áí áèèçà ðaçàèòèý ýèàèòðí ýí áðáàòè-áñèíé ñèñòáí Ū ñòðáí Ááèòèèñèíáí í í ðý á òñèí áèýò èèááðáèèçí ááí í í áí ðŷí èá ýèàèòðí ýí áðáèè.

Áí í í èí áí í áý í í ááèü í í çáí èýáò ááòáèü í áí áèèçèðí ááòü ýèàèòðí ñèñòáí Ū è ñèñòáí Ū òðáí ñí í ð-òèðí áèè í ðèðí áí í áí áàça (á ò. +. è í áæí áòèí í áèü-í ŷá), à òáèæá í áñòí ŷá ñèñòáí Ū òáí èí ñí ááæáí èý. Ņí çááí í áí í í èí áí èá è í ðèáèí áèü í é í í ááèè „Ņáòü“, ááá áèý èáæáí áí ñááí áí òá ñáòè í ðèáí áýòñý í ñí í áí ŷá òáóí èèí-ýèí í í í è-áñèèá í áðáí áòðü.

Áí í í èí áí èá è í í ááèè í í çáí èýáò í ðí ááñòè í ðááááðèòáèüí ŷé áí áèèç í ðè í ðí èèááèá í í á ŷò èèè ðáèí í ñòðòèòèè ñòáðŷò òðóáí í ðí áí áí á òáí òðá-èèçí ááí í í áí òáí èí ñí ááæáí èý, í ðè òñòáí í áèáí èè í í á ŷò è í ðí ááðèá æèçí áñí í ñí áí í ñòè ñòáðŷò ááí áðèðòþùèò í í ū í í ñòáè. Ėðí í á òí áí, í í á í í çáí èýáò í í ðáááèèòü áí çááèñòáèá áðáòèèí á ýèàèòðè-áñèíé è òáí èí áí é í ááðòóçèè í á ñèñòáí ó, à òáèæá òáèáñí í áðçáí í ñòü ðáèí í ñòðòèòèè çááí èé á òáèýò ñí èæáí èý í í òáðü òáí èá è áí çááèñòáèý ýòí áí í á ñèñòáí ó á òáèí í.

Á ñòáòüá í òáí áí á ñèòóáòèý ýí áðáàòè-áñèíáí ñáèòí ðá Ėèòáŷ. Í á í ðèí áðá í áí í áí áí ðí áá Ėèòáŷ ñ èñí í èüçí ááí èáì ñí çááí í í é í í ááèè í ðááèí æáí Ū í óòè ðaçàèòèý òáí èí ñí ááæáí èý: í í á ŷá èí òèŷ, í í ááý ŌÝŌ, ðáèí í ñòðòèòèý òáí èí á ŷò òðóáí-í ðí áí áí á, ðáèí í ñòðòèòèý çááí èé ñ òáèüþ ñí èçèòü í í òáðè òáí èá, à òáèæá ááòáí òðáèèçàòèý òáí èí-ñí ááæáí èý.

Ėèþ-ááŷá ñèí áá: í áòáí àðè-áñèáý í í ááèü, ñáòè, òáí òðáèèçí ááí í í á òáí èí ñí ááæáí èá, ýèàèòðí ñèñòáí á, ñáòè è ðèðí áí í áí áàça